

Intellimod™ Module Dual-In-Line Intelligent Power Module 5 Amperes/600 Volts

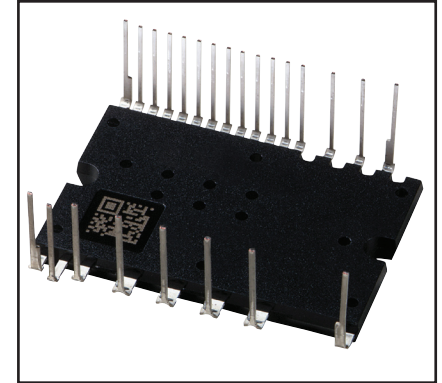
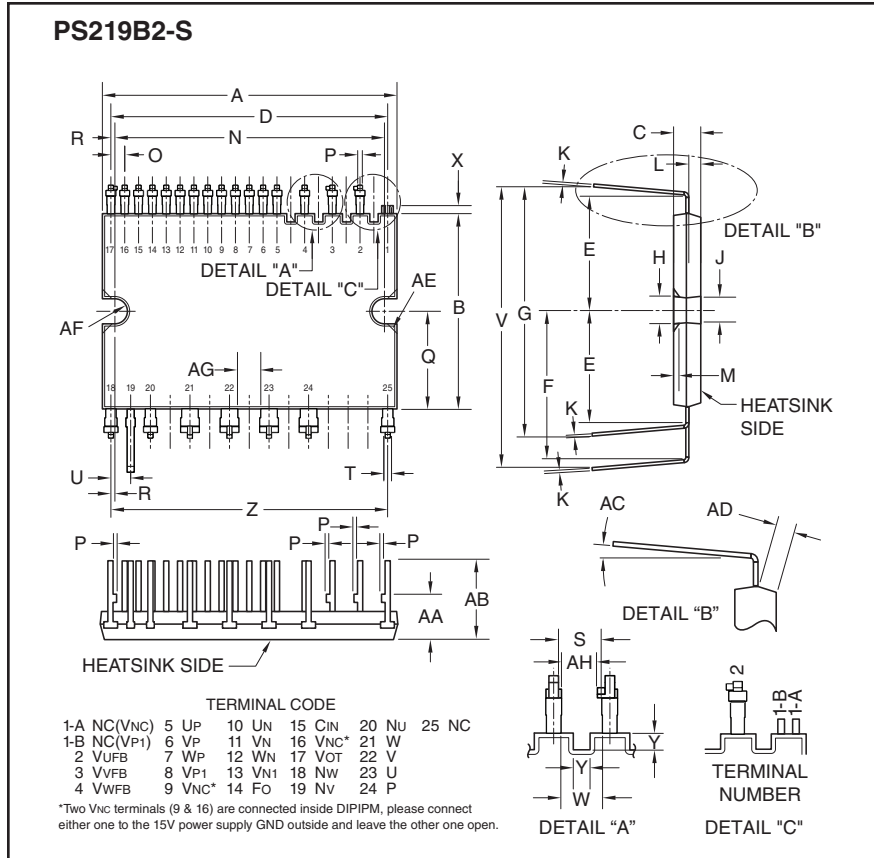

Description:

DIP-IPMs are intelligent power modules that integrate power devices, drivers, and protection circuitry in an ultra compact dual-in-line transfer-mold package for use in driving small three phase motors. Use of 6th generation CSTBT IGBTs, DIP packaging, and application specific HVICs allow the designer to reduce inverter size and overall design time.

Features:

- Compact Packages
- Single Power Supply
- Integrated HVICs
- Direct Connection to CPU
- Linear, Analog Temperature Feedback

Applications:

- Small Servo Motors
- Small Motor Control

Ordering Information:

PS219B2-S is a 600V, 5 Ampere short pin DIP Intelligent Power Module.

PS219B2-AS – long pin type
PS219B2-CS – zigzag pin type

Outline Drawing and Circuit Diagram

Dim.	Inches	Millimeters
A	1.50±0.02	38.0±0.5
B	0.94±0.02	24.0±0.5
C	0.14	3.5
D	1.40	35.56
E	0.57±0.02	14.4±0.5
F	0.74±0.02	18.9±0.5
G	1.15±0.02	29.2±0.5
H	0.14	3.5
J	0.13	3.3
K	0.016	0.4
L	0.06±0.02	1.5±0.05
M	0.031	0.8
N	1.38±0.019	35.0±0.3
O	0.07±0.008	1.778±0.2
P	0.02	0.5
Q	0.47	12.0
R	0.011	0.28

Dim.	Inches	Millimeters
S	0.1046	2.656
T	0.024	0.6
U	0.1±0.008	2.54±0.2
V	1.33±0.02	33.7±0.5
W	0.1085	2.756
X	0.04	1.0
Y	0.05	1.2
Z	1.40	35.56
AA	0.22±0.02	5.5±0.5
AB	0.37±0.02	9.5±0.5
AC	0 ~ 5°	0 ~ 5°
AD	0.06 Min.	1.5 Min.
AE	0.05	1.2
AF	0.063 Rad.	1.6 Rad.
AG	0.118 Min.	3.0 Min.
AH	0.098 Min.	2.5 Min.

PS219B2-S, PS219B2-AS, PS219B2-CS
Intellimod™ Module
Dual-In-Line Intelligent Power Module
 5 Amperes/600 Volts

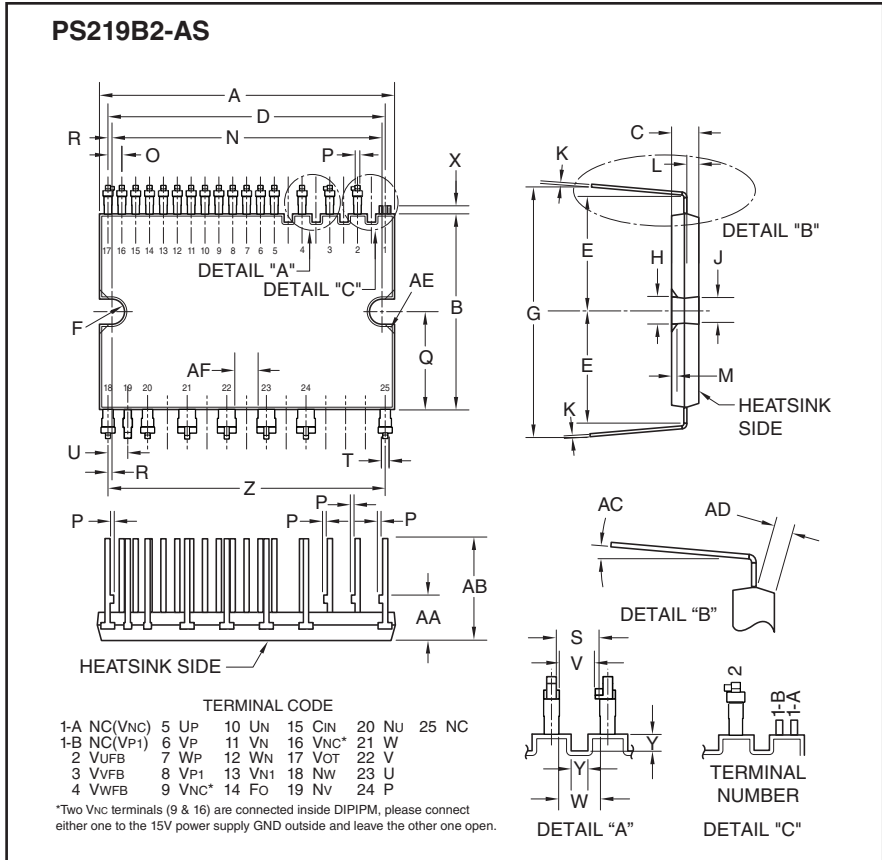

Outline Drawing and Circuit Diagram

Dim.	Inches	Millimeters
A	1.50±0.02	38.0±0.5
B	0.94±0.02	24.0±0.5
C	0.14	3.5
D	1.40	35.56
E	0.57±0.02	14.4±0.5
F	0.063 Rad.	1.6 Rad.
G	1.16±0.02	29.4±0.5
H	0.14	3.5
J	0.13	3.3
K	0.016	0.4
L	0.06±0.02	1.5±0.05
M	0.031	0.8
N	1.38±0.019	35.0±0.3
O	0.07±0.008	1.778±0.2
P	0.02	0.5
Q	0.47	12.0

Dim.	Inches	Millimeters
R	0.011	0.28
S	0.1046	2.656
T	0.024	0.6
U	0.1±0.008	2.54±0.2
V	0.098 Min.	2.5 Min.
W	0.1085	2.756
X	0.04	1.0
Y	0.05	1.2
Z	1.40	35.56
AA	0.22±0.02	5.5±0.5
AB	0.55±0.02	14.0±0.5
AC	0 ~ 5°	0 ~ 5°
AD	0.06 Min.	1.5 Min.
AE	0.05	1.2
AF	0.118 Min.	3.0 Min.

PS219B2-S, PS219B2-AS, PS219B2-CS
Intellimod™ Module
Dual-In-Line Intelligent Power Module
 5 Amperes/600 Volts

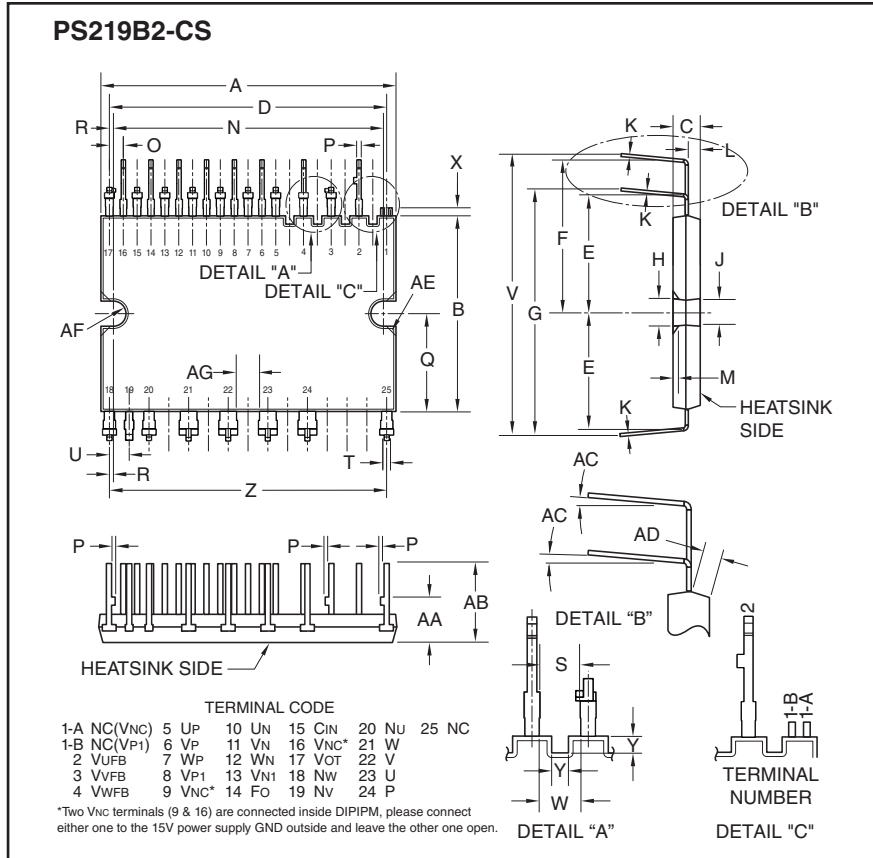

Outline Drawing and Circuit Diagram

Dim.	Inches	Millimeters
A	1.50±0.02	38.0±0.5
B	0.94±0.02	24.0±0.5
C	0.14	3.5
D	1.40	35.56
E	0.57±0.02	14.4±0.5
F	0.74±0.02	18.9±0.5
G	1.15±0.02	29.2±0.5
H	0.14	3.5
J	0.13	3.3
K	0.016	0.4
L	0.06±0.02	1.5±0.05
M	0.031	0.8
N	1.38±0.019	35.0±0.3
O	0.07±0.008	1.778±0.2
P	0.02	0.5
Q	0.47	12.0

Dim.	Inches	Millimeters
R	0.011	0.28
S	0.1046	2.656
T	0.024	0.6
U	0.1±0.008	2.54±0.2
V	1.33±0.02	33.7±0.5
W	0.1085	2.756
X	0.04	1.0
Y	0.05	1.2
Z	1.40	35.56
AA	0.22±0.02	5.5±0.5
AB	0.37±0.02	9.5±0.5
AC	0 ~ 5°	0 ~ 5°
AD	0.06 Min.	1.5 Min.
AE	0.05	1.2
AF	0.063 Rad.	1.6 Rad.
AG	0.118 Min.	3.0 Min.

PS219B2-S, PS219B2-AS, PS219B2-CS
Intellimod™ Module
Dual-In-Line Intelligent Power Module
 5 Amperes/600 Volts

Absolute Maximum Ratings, $T_j = 25^\circ\text{C}$ unless otherwise specified

Characteristics	Symbol	PS219B2-S, PS219B2-AS, PS219B2-CS	
			Units
Inverter Part			
Supply Voltage (Applied between P-NU, NV, NW)	V_{CC}	450	Volts
Supply Voltage, Surge (Applied between P-NU, NV, NW)	$V_{CC(\text{surge})}$	500	Volts
Collector-Emitter Voltage	V_{CES}	600	Volts
Each IGBT Collector Current ($T_C = 25^\circ\text{C}$)	$\pm I_C$	5	Amperes
Each Peak Collector Current ($T_C = 25^\circ\text{C}$, Less than 1ms)	$\pm I_{CP}$	10	Amperes
Collector Dissipation ($T_C = 25^\circ\text{C}$, per 1 Chip)	P_C	21.3	Watts
Power Device Junction Temperature*1	T_j	-20 ~ +150	$^\circ\text{C}$

Control (Protection) Part

Control Supply Voltage (Applied between $V_{P1-V_{NC}}$, $V_{N1-V_{NC}}$)	V_D	20	Volts
Control Supply Voltage (Applied between V_{UFB-U} , V_{VFB-V} , V_{WFB-W})	V_{DB}	20	Volts
Input Voltage (Applied between U_P , V_P , W_P-V_{NC} , U_N , V_N , W_N-V_{NC})	V_{IN}	-0.5 ~ $V_D+0.5$	Volts
Fault Output Supply Voltage (Applied between F_O-V_{NC})	V_{FO}	-0.5 ~ $V_D+0.5$	Volts
Fault Output Current (Sink Current at F_O Terminal)	I_{FO}	1	mA
Current Sensing Input Voltage (Applied between $C_{IN-V_{NC}}$)	V_{SC}	-0.5 ~ $V_D+0.5$	Volts

Total System

Self-protection Supply Voltage Limit, Short Circuit Protection Capability ($V_D = 13.5 \sim 16.5\text{V}$, Inverter Part, $T_j = 125^\circ\text{C}$, Non-repetitive less than $2\mu\text{s}$)	$V_{CC(\text{prot.})}$	400	Volts
Module Case Operating Temperature*2	T_C	-20 ~ +100	$^\circ\text{C}$
Storage Temperature	T_{stg}	-40 ~ +125	$^\circ\text{C}$
Isolation Voltage, 60Hz, Sinusoidal 1 Minute, All Connected Pins to Heatsink Plate	V_{ISO}	1500	V_{rms}

Thermal Resistance

Junction to Case*3	$R_{th(j-c)Q}$	Inverter IGBT Part (Per 1/6 Module)	—	—	4.7	$^\circ\text{C/Watt}$
	$R_{th(j-c)D}$	Inverter FWDi Part (Per 1/6 Module)	—	—	5.4	$^\circ\text{C/Watt}$

*1 The maximum junction temperature rating of the power chips integrated within the DIPIPM is 150°C ($@T_C \leq 100^\circ\text{C}$). However, to ensure safe operation of the DIPIPM, the average junction temperature should be limited to $T_{j(\text{avg})} \leq 125^\circ\text{C}$ ($@T_C \leq 100^\circ\text{C}$).

*2 TC measurement point

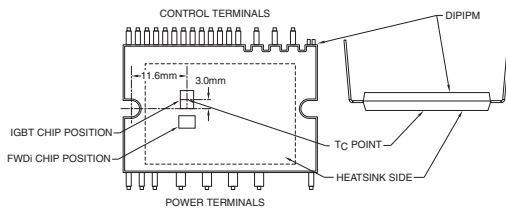

*3 Good thermal grease with long-term quality should be applied evenly with $+100\mu\text{m} \sim +200\mu\text{m}$ on the contacting surface of the DIPIPM and heatsink. The contacting thermal resistance between DIPIPM case and heatsink ($R_{th(c-f)}$) is determined by the thickness and the thermal conductivity of the applied grease. For reference, $R_{th(c-f)}$ (per 1/6 module) is about 0.3°C/W when the grease thickness is $20\mu\text{m}$ and the thermal conductivity is 1.0W/mK .

PS219B2-S, PS219B2-AS, PS219B2-CS
Intellimod™ Module
Dual-In-Line Intelligent Power Module
 5 Amperes/600 Volts

Electrical and Mechanical Characteristics, $T_j = 25^\circ\text{C}$ unless otherwise specified

Characteristics	Symbol	Test Conditions	Min.	Typ.	Max.	Units	
Inverter Part							
Collector-Emitter Saturation Voltage	$V_{CE(sat)}$	$V_D = V_{DB} = 15\text{V}, I_C = 5\text{A}, V_{IN} = 5\text{V}, T_j = 25^\circ\text{C}$	—	1.50	2.00	Volts	
		$V_D = V_{DB} = 15\text{V}, I_C = 5\text{A}, V_{IN} = 5\text{V}, T_j = 125^\circ\text{C}$	—	1.60	2.10	Volts	
Diode Forward Voltage	V_{EC}	$-I_C = 5\text{A}, V_{IN} = 0\text{V}$	—	1.70	2.20	Volts	
Switching Times	t_{on}		0.75	1.35	1.95	μs	
	t_{rr}	$V_{CC} = 300\text{V}, V_D = V_{DB} = 15\text{V},$	—	0.30	—	μs	
	$t_{C(on)}$	$I_C = 5\text{A}, T_j = 125^\circ\text{C},$	—	0.35	0.55	μs	
	t_{off}	$V_{IN} = 0 \leftrightarrow 5\text{V}, \text{Inductive Load}$	—	1.40	2.00	μs	
	$t_{C(off)}$		—	0.30	0.60	μs	
Collector-Emitter Cutoff Current	I_{CES}	$V_{CE} = V_{CES}, T_j = 25^\circ\text{C}$	—	—	1.0	mA	
		$V_{CE} = V_{CES}, T_j = 125^\circ\text{C}$	—	—	10	mA	
Control (Protection) Part							
Circuit Current	I_D	$V_{IN} = 0\text{V}, V_D = 15\text{V}$	Total of $V_{P1}-V_{NC}, V_{N1}-V_{NC}$	—	—	2.80	mA
		$V_{IN} = 5\text{V}, V_D = 15\text{V}$	Total of $V_{P1}-V_{NC}, V_{N1}-V_{NC}$	—	—	2.80	mA
	I_{DB}	$V_{IN} = 0\text{V}, V_D = V_{DB} = 15\text{V}$	Each Part of $V_{UFB-U}, V_{VFB-V}, V_{WFB-W}$	—	—	0.10	mA
		$V_{IN} = 5\text{V}, V_D = V_{DB} = 15\text{V}$	Each Part of $V_{UFB-U}, V_{VFB-V}, V_{WFB-W}$	—	—	0.10	mA
Fault Output Voltage	V_{FOH}	$V_{SC} = 0\text{V}, F_O$ Terminal Pull-up to 5V by 10k Ω	4.9	—	—	Volts	
	V_{FOL}	$V_{SC} = 1\text{V}, I_{FO} = 1\text{mA}$	—	—	0.95	Volts	
Input Current	I_{IN}	$V_{IN} = 5\text{V}$	0.70	1.00	1.50	mA	
Short Circuit Trip Level	$V_{SC(ref)}$	$V_D = 15\text{V}^{*4}$	0.43	0.48	0.53	Volts	
Temperature Output	V_{OT}	LVIC Temperature = 90 $^\circ\text{C}$	2.63	2.77	2.91	Volts	
Pull Down R = 5k Ω ^{*6}		LVIC Temperature = 25 $^\circ\text{C}$	0.88	1.13	1.39	Volts	
Control Supply	UV_{DBt}	Trip Level, $T_j \leq 125^\circ\text{C}$	7.0	10.0	12.0	Volts	
Under-voltage Protection	UV_{DBr}	Reset Level, $T_j \leq 125^\circ\text{C}$	7.0	10.0	12.0	Volts	
	UV_{Dt}	Trip Level, $T_j \leq 125^\circ\text{C}$	10.3	—	12.5	Volts	
	UV_{Dr}	Reset Level, $T_j \leq 125^\circ\text{C}$	10.8	—	13.0	Volts	
Fault Output Pulse Width ^{*5}	t_{FO}		20	—	—	μs	
ON Threshold Voltage	$V_{th(on)}$	Applied between	—	2.1	2.6	Volts	
OFF Threshold Voltage	$V_{th(off)}$	$U_P, V_P, W_P-V_{NC},$	0.8	1.3	—	Volts	
ON/OFF Threshold Hysteresis Voltage	$V_{th(hys)}$	U_N, V_N, W_N-V_{NC}	0.35	0.65	—	Volts	
Bootstrap Diode Forward Voltage ^{*7}	V_F	$I_F = 10\text{mA},$	1.1	1.7	2.3	Volts	
Including Voltage Drop by Limiting Resistor							
Built-in Limiting Resistance	R	For Bootstrap Circuit	80	100	120	Ω	

^{*4} Short Circuit protection is functioning only for N-side IGBTs. Please select the value of the external shunt resistor such that the SC trip level is less than 1.7 times the current rating.

^{*5} Fault signal, FO, outputs when SC or UV protection works. FO pulse width is different for each protection mode. At SC failure, FO pulse width is a fixed width (=min. 20 μs), however, at UV failure, FO outputs continuously until recovering from UV state. Minimum FO pulse width is 20 μs .

PS219B2-S, PS219B2-AS, PS219B2-CS
Intellimod™ Module
Dual-In-Line Intelligent Power Module
 5 Amperes/600 Volts

*6 The DIPIPM does not automatically shutdown the IGBTs and fault signal when temperature rises excessively. When the temperature exceeds the protective level that is defined by the user, the controller (MCU) should stop the DIPIPM. The temperature of LVIC vs. VOT output characteristics is shown in the following graph. VOT output may exceed 3.3V when the temperature rises excessively, therefore, it is recommended for protection of the control part (MCU) to insert a clamp diode between the control supply (3.3V) and VOT output.

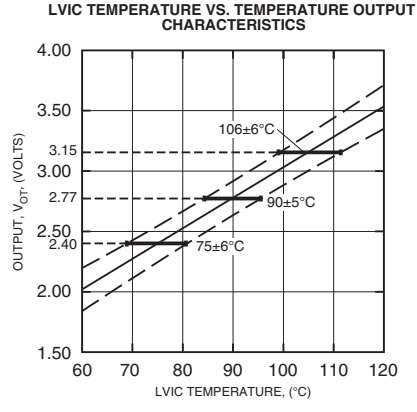

*7 Bootstrap Diode (@Ta = 25°C) Characteristics

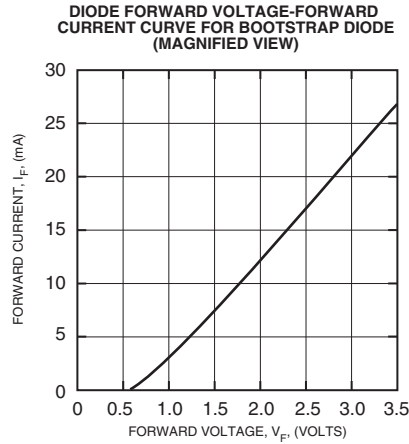
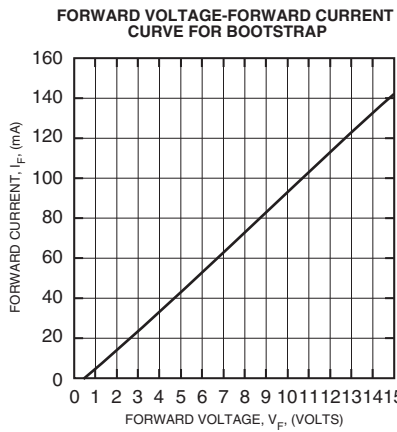

PS219B2-S, PS219B2-AS, PS219B2-CS
Intellimod™ Module
Dual-In-Line Intelligent Power Module
 5 Amperes/600 Volts

Mechanical Characteristics and Ratings

Characteristic	Symbol	Condition	Min.	Typ.	Max.	Units
Mounting Torque		M3 Mounting Screws* ⁸	5.2	6.1	6.9	in-lb
Terminal Pulling Strength		Control Terminal: Weight 4.9N Power Terminal: Weight 9.8N	10	—	—	s
Terminal Bending Strength		Control Terminal: Weight 2.45N Power Terminal: Weight 4.9N 90 Degree Bend	2	—	—	times
Module Weight (Typical)			—	8.5	—	Grams
Heatsink Flatness* ⁹			-50	—	+100	μm

Recommended Conditions for Use

Characteristic	Symbol	Condition	Min.	Typ.	Max.	Units
Supply Voltage	V_{CC}	Applied between P-N Terminals	0	300	400	Volts
Control Supply Voltage	V_D	Applied between V_{P1} - V_{NC} , V_{N1} - V_{NC}	13.5	15.0	16.5	Volts
	V_{DB}	Applied between V_{UFB} -U, V_{VFB} -V, V_{WFB} -W	13.0	15.0	18.5	Volts
Control Supply Variation	ΔV_D , ΔV_{DB}		-1	—	1	V/μs
Arm Shoot-through Blocking Time	t_{DEAD}	For Each Input Signal, $T_C \leq 100^\circ\text{C}$	1.0	—	—	μs
Allowable Minimum Input	$P_{WIN(on)}$		0.7	—	—	μs
Pulse Width* ¹¹	$P_{WIN(off)}$		0.7	—	—	μs
V_{NC} Voltage Variation	V_{NC}	Between V_{NC} -NU, NV, NW (Including Surge)	-5.0	—	5.0	Volts
Junction Temperature	T_j		-20	—	125	°C

*⁸ Plain washers (ISO 7089-7094) are recommended.

*⁹ Flatness measurement position.

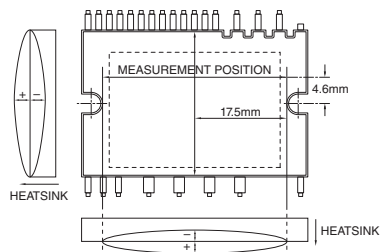

*¹¹ DIIPM may not respond if the input signal pulse is less than $P_{WIN(on)}$, $P_{WIN(off)}$.

PS219B2-S, PS219B2-AS, PS219B2-CS
Intellimod™ Module
Dual-In-Line Intelligent Power Module
 5 Amperes/600 Volts

Application Circuit

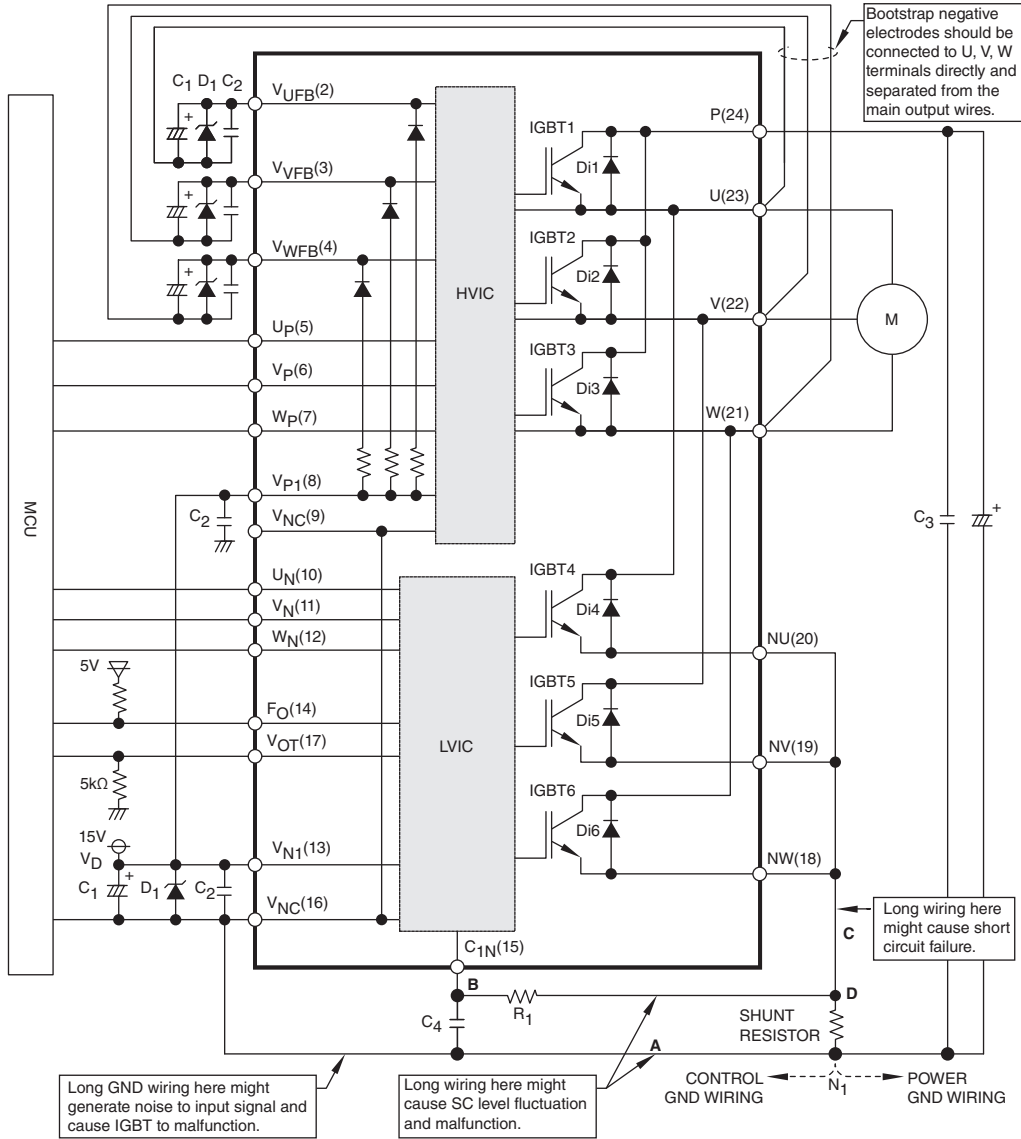

Notes:

- 1) It is recommended to connect Control GND wiring and Power GND wiring only at point N₁ (near terminal of shunt resistor) to prevent a malfunction by Power GND fluctuations.
- 2) It is recommended to insert a Zener diode D1 (24V/1W) between each pair of control supply terminals to prevent surge destruction.
- 3) To prevent surge destruction, the wiring between the DC bus smoothing capacitor and the P, N₁ terminals should be as short as possible. Generally a 0.1-0.22μF snubber capacitor C3 between the P-N₁ terminals is recommended.
- 4) Time constant of R₁, C₄ for SC protection circuit should be selected so that protection works within 2μs. (Recommended value: ≤2μs) SC interrupting time might vary with the wiring pattern. Tight tolerance, temp-compensated type, is recommended for R₁, C₄.
- 5) To prevent malfunction, the wiring of A, B, C should be as short as possible.
- 6) The point D at which the wiring to C_{1N} filter is divided should be near the terminal of shunt resistor. NU, NV, NW terminals should be connected at near NU, NV, NW terminals.
- 7) All capacitors should be mounted as close to the terminals as possible. (C1: good temperature, frequency characteristic electrolytic type and C2: 0.22μ-2μF, good temperature, frequency and DC bias characteristic ceramic types recommended.)
- 8) Input drive is active-high type. There is a 3.3kΩ (Min.) pull-down resistor in the input circuit of IC. To prevent malfunction, the wiring of each input should be as short as possible. When using RC coupling circuit, make sure the input signal level meets the turn-on and turn-off threshold voltage.
- 9) F_O output is open drain type. It should be pulled up to MCU or control power supply (e.g. 5V) by resistor makes I_{F_O} up to 1mA.
- 10) Direct coupling to the MCU without any opto-coupler or transformer isolation is possible because the HVIC is inside the module.
- 11) Two V_{NC} terminals (9 & 16 pin) are connected inside the DIPIM. Be sure to connect either one to the 15V power supply GND outside and leave the other one open.
- 12) IC malfunction can occur and cause the DIPIM to operate erroneously when high frequency noise is superimposed on the control supply line. To avoid such problem, the line ripple voltage should meet dV/dt ≤ ±1V/μs and V_{ripple} ≤ 2Vp-p.

PS219B2-S, PS219B2-AS, PS219B2-CS
 Intellimod™ Module
 Dual-In-Line Intelligent Power Module
 5 Amperes/600 Volts

Protection Function Timing Diagrams

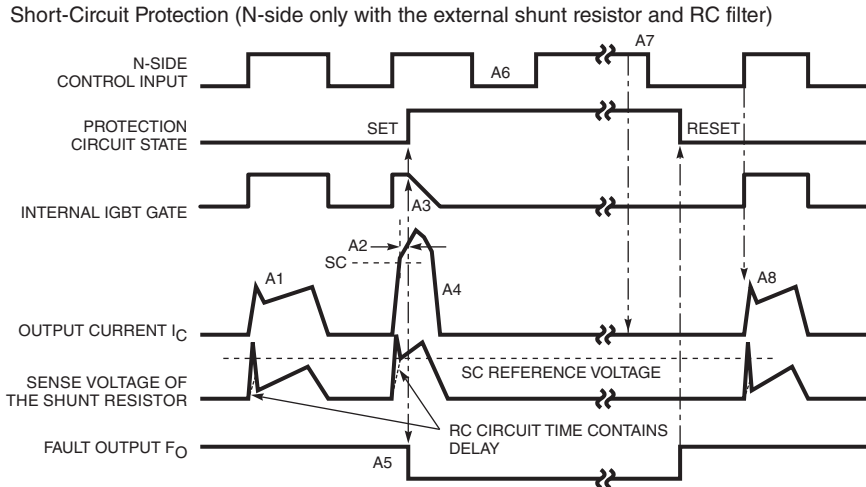

- A1: Normal operation – IGBT turn on and conducting current.
- A2: Short-circuit current detected (SC trigger).
- A3: All N-side IGBT gate hard interrupted.
- A4: All N-side IGBTs turn off.
- A5: F_O output with a fixed pulse width of $t_{FO(min)} = 20\mu s$.
- A6: Input "L" – IGBT off.
- A7: Input "H" – IGBT off in spite of "H" input.
- A8: Normal operation – IGBT on and conducting current.

Under-Voltage Protection (N-side, UV_D)

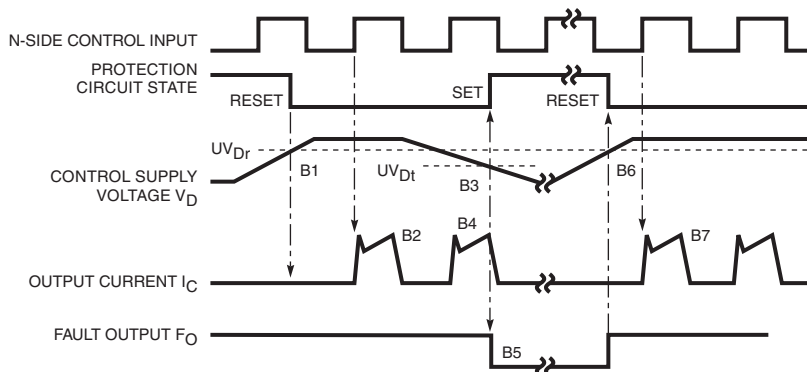

- B1: Control supply voltage rise – After the voltage level reaches UV_{Dr} , the drive circuit begins to work at the rising edge of the next input signal.
- B2: Normal operation – IGBT turn on and conducting current.
- B3: Under-voltage trip (UV_{Dt}).
- B4: All N-side IGBTs turn off regardless of the control input level.
- B5: F_O output during under-voltage period, however, the minimum pulse width is $20\mu s$.
- B6: Under-voltage reset (UV_{Dr}).
- B7: Normal operation – IGBT turn on and conducting current.

PS219B2-S, PS219B2-AS, PS219B2-CS
 Intellimod™ Module
 Dual-In-Line Intelligent Power Module
 5 Amperes/600 Volts

Protection Function Timing Diagrams

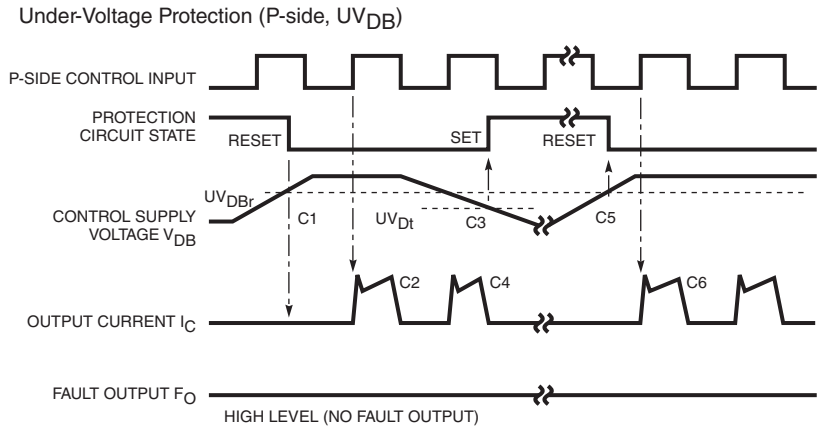

- C1: Control supply voltage rises – After the voltage level reaches UV_{DBr} , the drive circuit begins to work at the rising edge of the next input signal.
- C2: Normal operation – IGBT turn on and conducting current.
- C3: Under-voltage trip (UV_{DBt}).
- C4: IGBT stays off regardless of the control input level, but there is no F_O signal output.
- C5: Under-voltage reset (UV_{DBr}).
- C6: Normal operation – IGBT turn on and conducting current.

Typical Interface Circuit

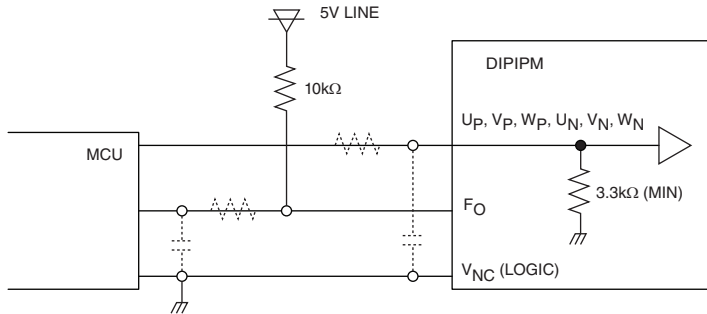

NOTE: RC coupling at each input (parts shown dotted) may change depending on the PWM control scheme used in the application and the wiring impedance of the printed circuit board. The DIPIPM input signal section integrates a 3.3kΩ (min) pull-down resistor. Therefore, when using an external filtering resistor, care must be taken to satisfy the turn-on threshold voltage requirement.

Pattern Wiring Around Shunt Resistor

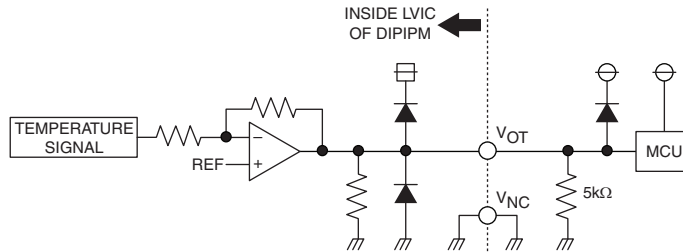

NOTE: V_{OT} outputs the analog signal that is amplified signal of temperature detecting element on LVIC by inverting amplifier.

It is recommended to insert a 5kΩ pull down resistor to obtain linear output characteristics at lower temperature than room temperature. When the pull down resistor is inserted between V_{OT} and V_{NC} (GND), the extra current calculated by V_{OT} output voltage/pull down resistance flows as additional LVIC circuit current continuously.

When the system controller supply is 3.3V, it is recommended to insert clamp Di between V_{CC} (MCU supply) and V_{OT} for preventing over voltage destruction of the system controller.

PS219B2-S, PS219B2-AS, PS219B2-CS
Intellimod™ Module
Dual-In-Line Intelligent Power Module
 5 Amperes/600 Volts

Pattern Wiring Around Shunt Resistor

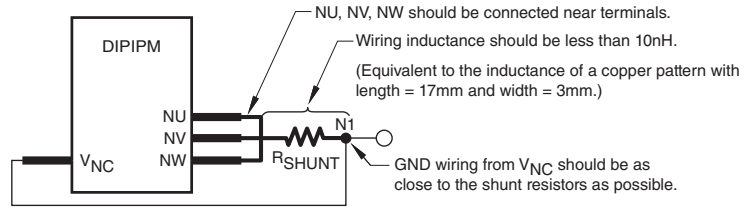

External S_C Protection Circuit Using Three Shunt Resistors

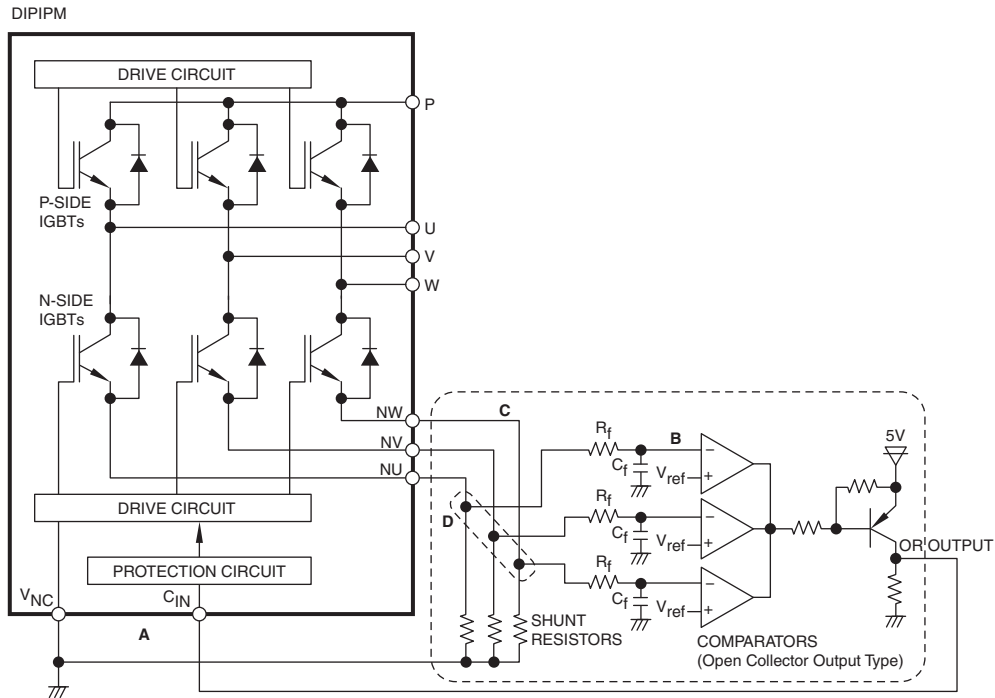

Notes:

- 1) It is necessary to set the time constraint R_f , C_f of external comparator input so that the IGBT stops within $2\mu\text{s}$ when short circuit occurs. SC interrupting time can vary with the wiring pattern, comparator speed and so on.
- 2) The threshold voltage V_{ref} should be set up as the same rating as the short circuit trip level ($V_{SC(ref)}$, typically 0.48V).
- 3) Select the external shunt resistance so that the SC trip-level is less than specified value (≤ 1.7 times current rating).
- 4) Wiring A, B, and C should be as short as possible to avoid a malfunction.
- 5) Where the wiring to the comparator is divided, point D, should be near the shunt resistor terminal.
- 6) OR output high level should be over 0.53V (= maximum $V_{SC(ref)}$).